

الصحة والخطأ

KAMAL_ELGBALAWY@YAHOO.COM

الأساليب الصحيحة لفرش السجاد أسفل الأثاث

مادة أسس التصميم الداخلي

الفرقة الرابعة - ٢٠٢٠/٢٠٢١

د.م/ كمال محمود الجبلأوي

THE REFERENCES TO MULTIPLE SOURCES ARE TEXT & FIGURES
(SKETCHES, DRAWINGS, PICTURES, PHOTOS,...ETC.)

ALL THE RIGHTS BELONG TO ORIGINAL AUTHORS

الأساليب الصحيحة لفرش السجاد أسفل الأثاث

الأساليب الصحيحة لفرش السجاد أسفل الأثاث

مقدمة عامة

السجاد أسفل الأثاث

PRINCIPALS
INTERIOR DESIGN

المراجع:

الصحيح والخطأ

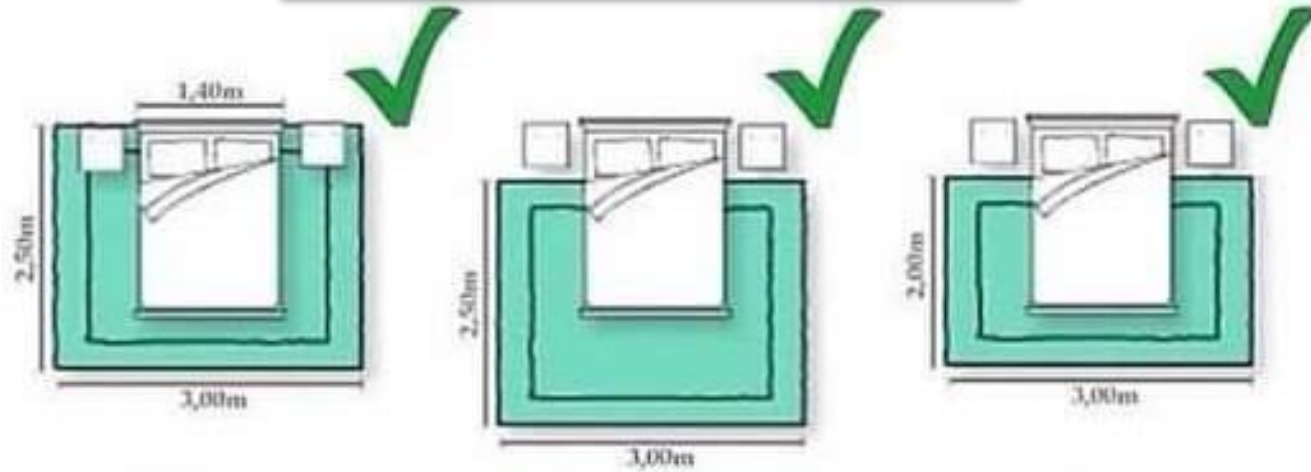

Dicas

Tapetes

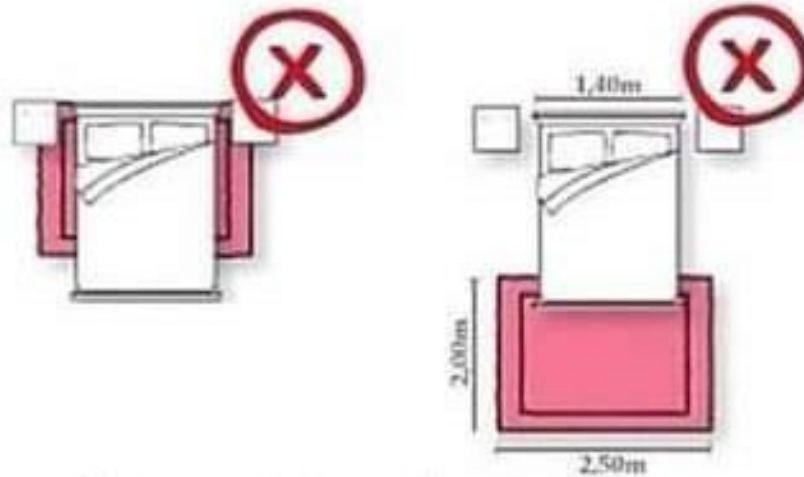
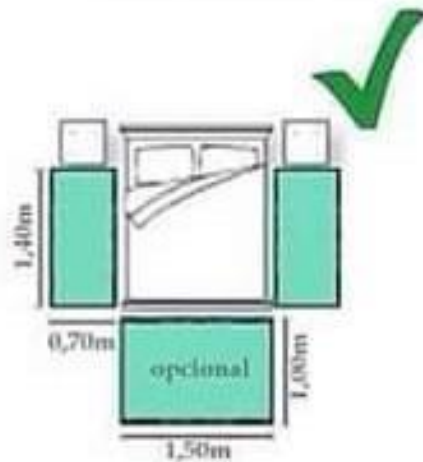

Ajustar as medidas de acordo com o tamanho da cama.
Ampliar o tapete aumenta a sensação de espaço do ambiente.

مقدمة عامة

السجاد أسفل الأثاث

PRINCIPALS
INTERIOR DESIGN

المراجع:

الصحيح والخطأ

BEDROOM

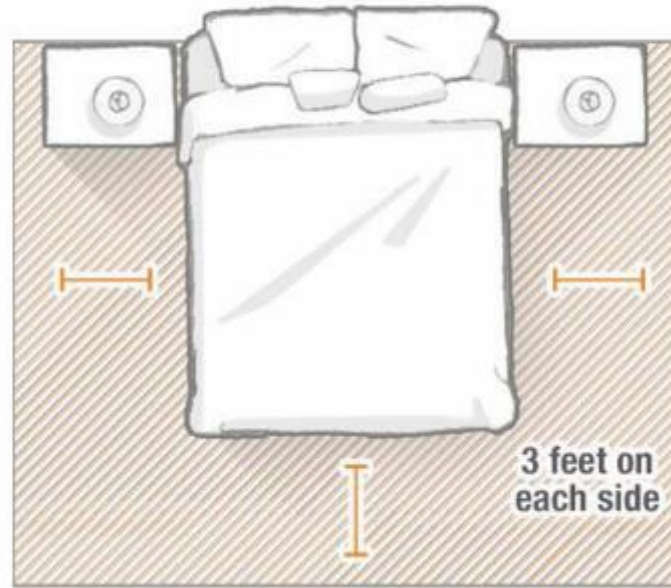

السجاد أسفل الأثاث

مقدمة عامة

السجاد أسفل الأثاث

PRINCIPALS
INTERIOR DESIGN

المراجع:

الصحيح والخاطئ

LIVING ROOM

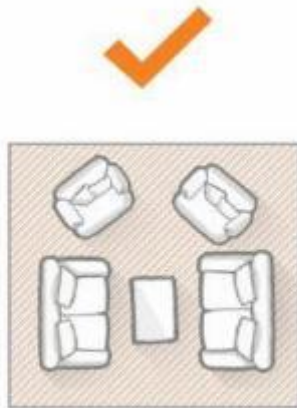
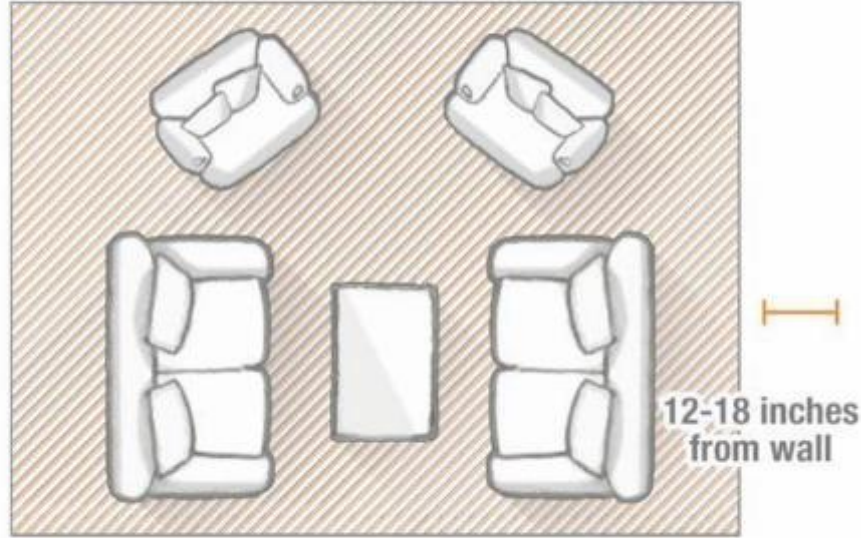

السجاد أسفل الأثاث

مقدمة عامة

السجاد أسفل الأثاث

PRINCIPALS
INTERIOR DESIGN

المراجع:

الصحيح والخطأ

DINING ROOM

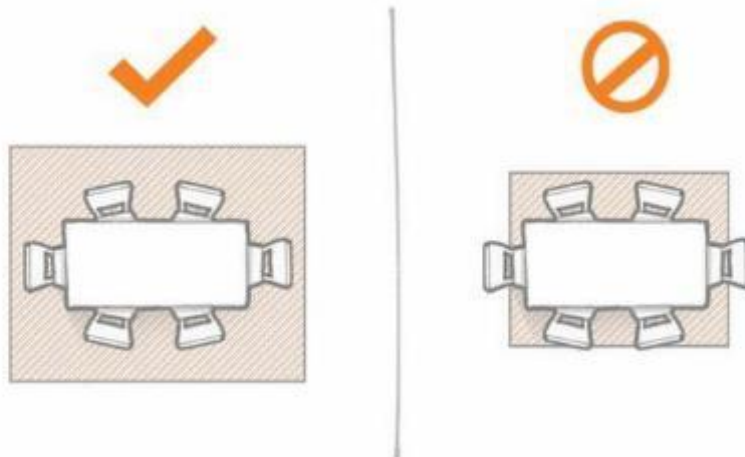
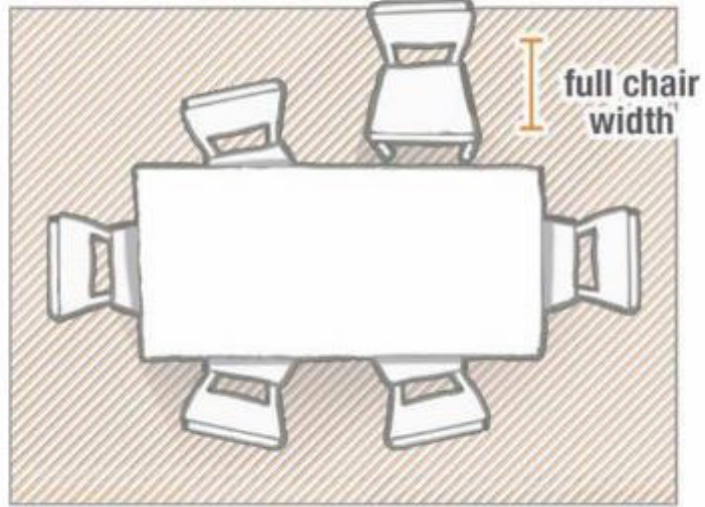

السجاد أسفل الأثاث

السجاد أسفل الأثاث

مقدمة عامة

السجاد أسفل الأثاث

PRINCIPALS
INTERIOR DESIGN

المراجع:

الصحيح والخطأ

GET YOUR RUGS

Right

BEDROOM

When placing a rug in your bedroom:

- Leave around a half-metre gap between your rug and your outer wall
- Ensure your rug sits underneath your bedside tables, or begins just after them
- Always have a proportionate amount of your rug protruding beyond the bed, like a picture frame. Having too much or too little on one side will make the room look unbalanced.

Don't



Do



“ Those with a standard sized room might want the rug to reach right up underneath their bedside tables, but it's not a necessity. The most important part of this look is that the rug disappears under the bed, giving the illusion of more space. For a standard sized room with a queen bed, an 8x10 rug will do the trick.”

Ben Dale - www.modern-rugs.co.uk

السجاد في الإسلام

السجاد في الإسلام

مقدمة عامة

السجاد أسفل الأثاث

PRINCIPALS
INTERIOR DESIGN

المراجع:

الصحيح والخطأ

LIVING ROOM

When placing a rug in your living room

- Never use a 'postage stamp' sized rug, the bigger the rug, the bigger your room will feel
- If your rug is big enough, have all four legs of furniture on the rug, for a more aesthetic finish
- At the very least, ensure that the front two legs of your surrounding chairs fit onto the rug

Don't



Do



“ A good rug can be a lifetime investment. When choosing your perfect rug, don't forget to think about your lifestyle, for example whether you have pets or small children. A silk fibre rug can help to maintain a fresh finish whilst wool is more practical for everyday living areas”

Charlie Bloom - www.stylenest.co.uk

<http://www.modern-rugs.co.uk/blog/>

السجاد من أهم عناصر الديكور الداخلي

السجاد من أهم عناصر الديكور الداخلي

مقدمة عامة

السجاد أسفل الأثاث

PRINCIPALS
INTERIOR DESIGN

المراجع:

DINING ROOM

When placing a rug in your dining room:

- Your dining chairs should always sit comfortably on the rug, even when pulled out.
- Add 60 centimetres onto each side of your dining table to find your optimal rug size.
- Choose a flat rug: if food and drink are spilled, these rugs are generally easier to clean. It's also much easier to move chairs on a flat or low-pile rug, and they're less susceptible to marks from the legs of heavy furniture.

Don't



Do



“ Getting a bigger rug that can be placed comfortably under furniture doesn't just make the space look larger, it also helps to create a warm cosy space that you and your guests will want to linger in”

Cate St Hill - www.catesthill.com

الصحيح والخطأ

do THIS:

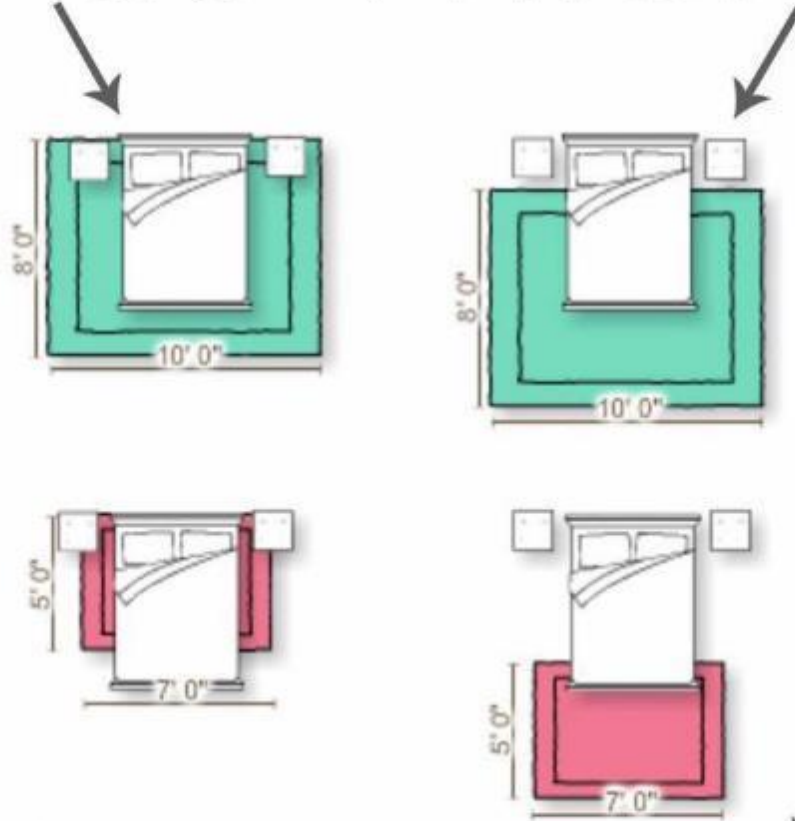

not THIS:

السجاد أسفل الأثاث

السجاد أسفل الأثاث

مقدمة عامة

السجاد أسفل الأثاث

PRINCIPALS
INTERIOR DESIGN

المراجع:

الصحيح والخطأ

do THIS:

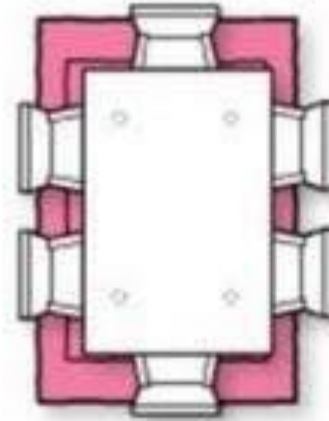
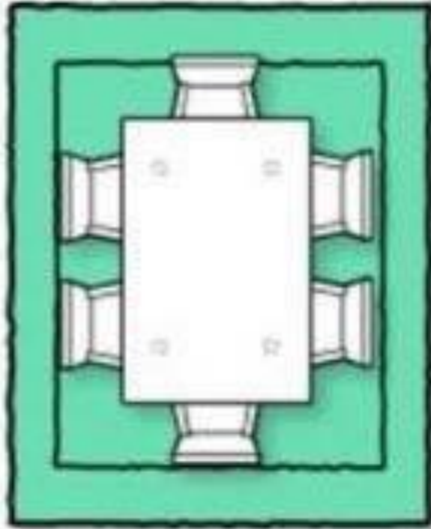
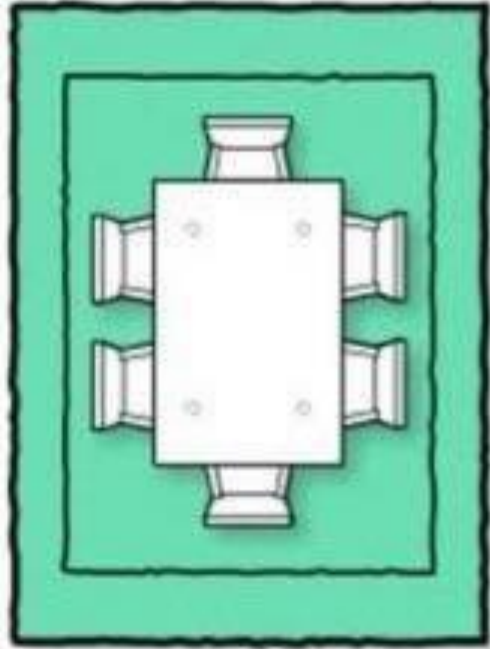

not THIS:

السجاد أسفل الأثاث

مقدمة عامة

السجاد أسفل الأثاث

PRINCIPALS
INTERIOR DESIGN

المراجع:

BEDROOM

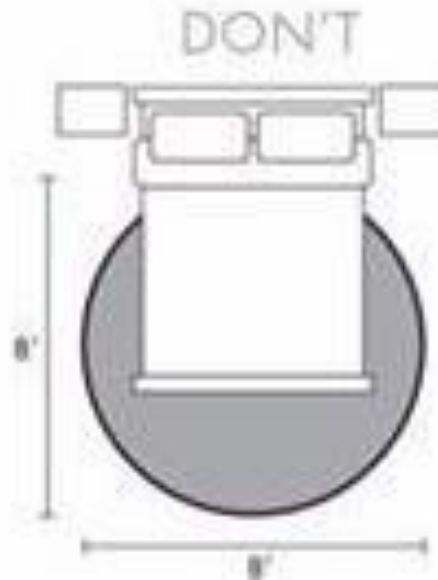
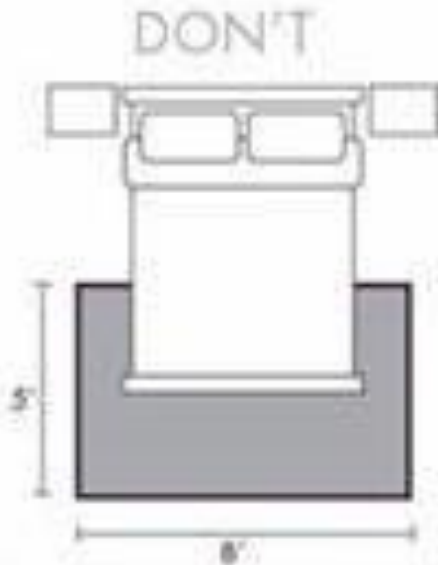
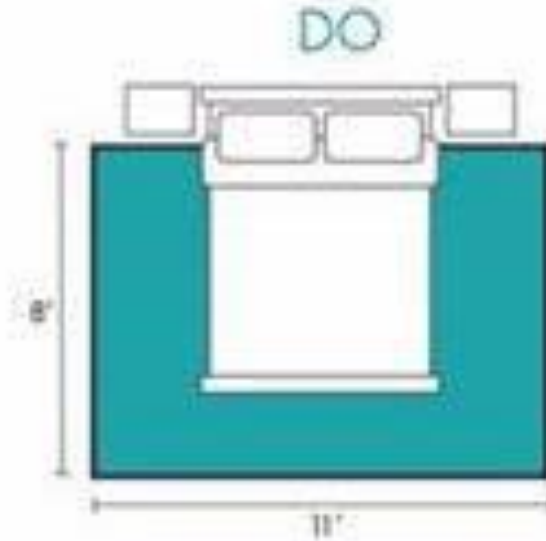
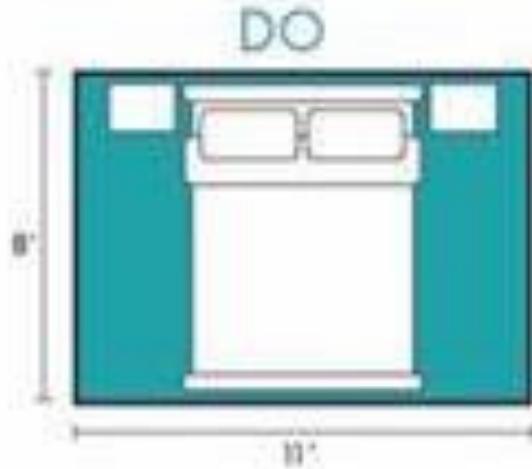

السجاد أسفل الأثاث

السجاد أسفل الأثاث

مقدمة عامة

السجاد أسفل الأثاث

PRINCIPALS
INTERIOR DESIGN

LIVING ROOM

DO

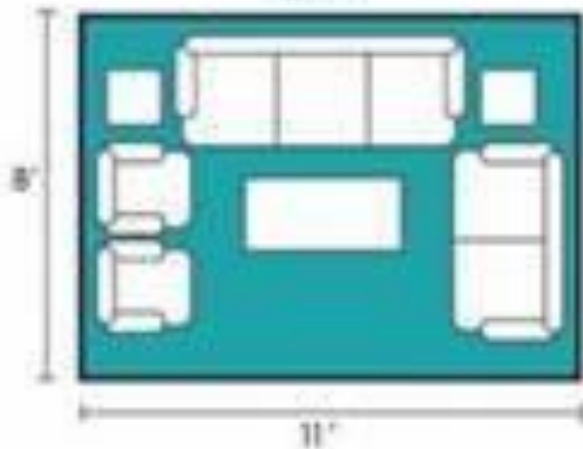

DO

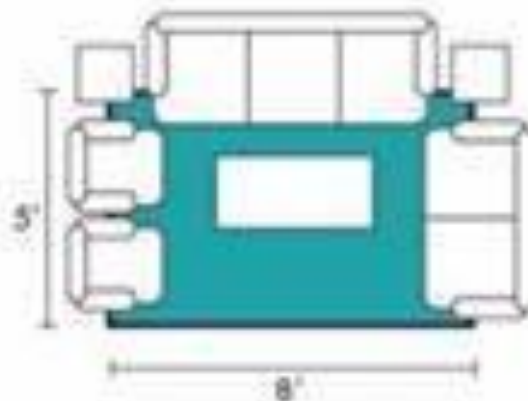

DON'T

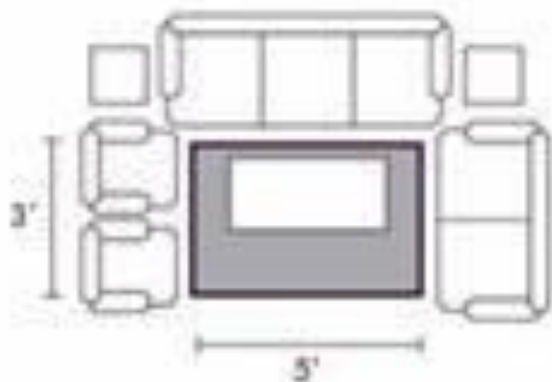

DON'T

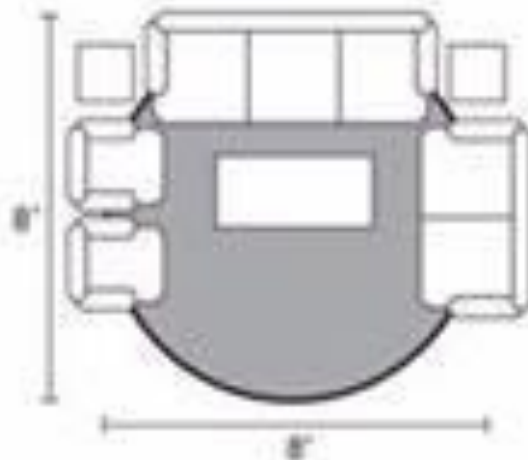

DINING ROOM

DO

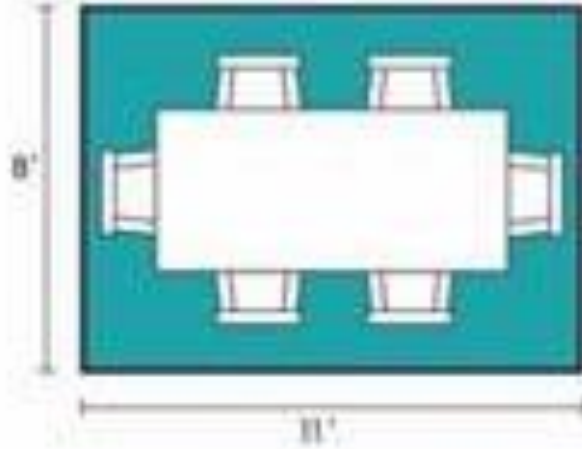

DO

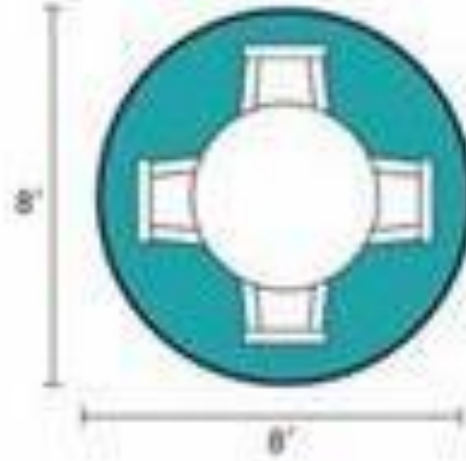

DON'T

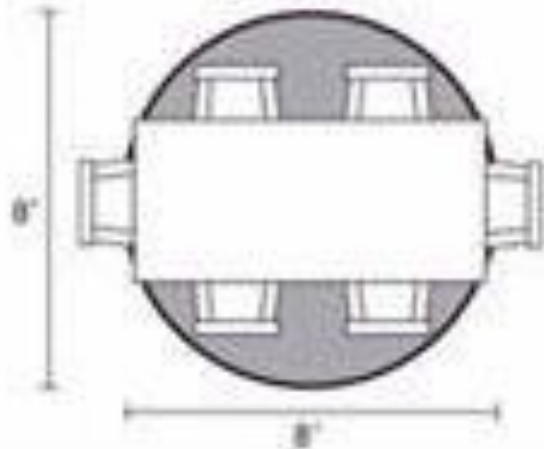

DON'T

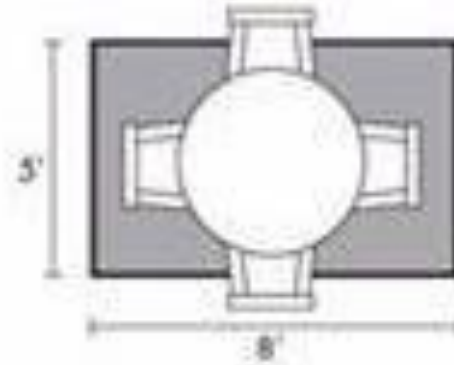

السجاد أسفل الأثاث

السجاد أسفل الأثاث

مقدمة عامة

السجاد أسفل الأثاث

PRINCIPALS
INTERIOR DESIGN

المراجع:



BEDROOM

Do This:



• For a spacious room, choose a rug large enough to hold the bed, provide extra width for walking on either side and at the end of the bed. Ideally, it should go under all furniture.

• Rug sizes to consider: 9'x12' for king, 8'x10' for queen

Or This:



• A slightly smaller room that comes just below the nightstands is also a "Do."

• Rug sizes to consider: 8'x10'

Not This:

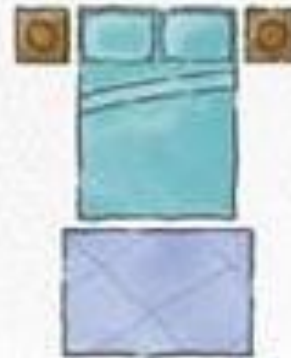

• Don't use a smaller rug centered around the foot of the bed. That looks like a postage stamp, and very out of scale. You want softness under your feet when you get out of bed!

• Rug sizes to avoid: 5'x8'

Try This:



• Another smart solution is using two small rugs on either side of the bed. This works particularly well if you have a dresser or desk on one side of your bed instead of a nightstand.

• Rug sizes to consider: 4'x6', 5'x5'

Try This:

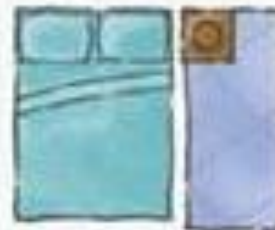

• For a bedroom with a bed in the corner, or in a room with two twin beds, choose a runner for along the side of the bed—it works great!

• Rug sizes to consider: 2'6" x 7'



LIVING ROOM

Do This:



• In a large room with a floating seating area, the rug should contain all pieces of furniture, including front and back legs, with space around.

• Rug sizes to consider:
10'x14', 9'x12'

Or This:



• If your sofa is up against a wall, ensure that at least the front legs of all furniture are on the rug.

• Rug sizes to consider:
8'x10', 5'x8' (if your furniture is sparse or petite.)

Not This:



• Skip a too-small rug that is only under the coffee table. Your feet should always rest on the rug when you're seated.

• Rug sizes to avoid:
5'x8' (if your furniture is large), 4'x6'



DINING ROOM

Do This:

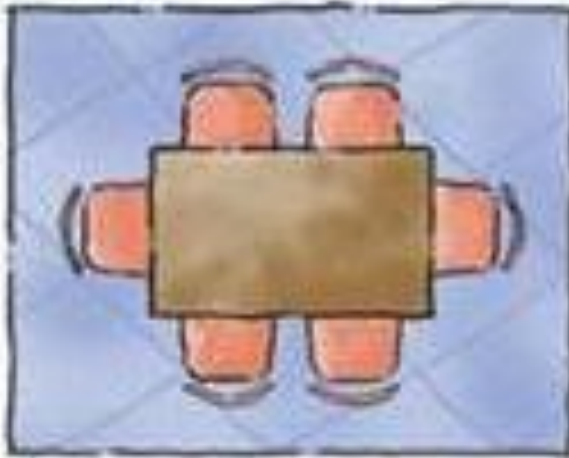

1 Choose a rug that generously holds your table and chairs even when they're pulled out from the table. It should have at least 24" of extra room on all sides.

2 Rug sizes to consider: 9'x12', 8'x10'

Not This:

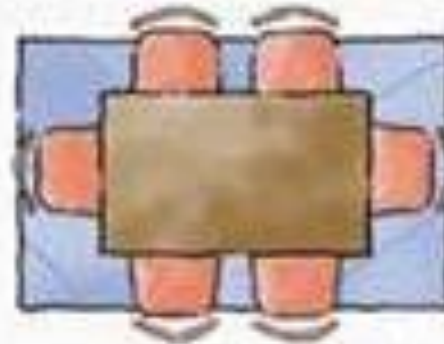

1 Avoid a too-small rug that barely contains the table and chairs.

2 Rug sizes to avoid: 5'x8', 4'x6'

Do This:



1 The same rules apply with a round table: The rug, whether circular or rectangular, should extend well passed the dining chairs.

2 Rug sizes to consider: 7' to 9' in diameter

Not This:



1 If a rug is too small, you risk guests tripping on it when pulling out their chairs.

2 Rug sizes to avoid: Anything less than 2x the diameter of your table.

الصحيح والخطأ

المجلس
الجلسة
الجلسات

المجلس
الجلسة
الجلسات

مقدمة عامة

السجاد أسفل الأثاث

PRINCIPALS
INTERIOR DESIGN



المراجع:

السجاد أسفل الأثاث

السجاد أسفل الأثاث

مقدمة عامة

السجاد أسفل الأثاث

PRINCIPALS
INTERIOR DESIGN

المراجع:

TOO SMALL

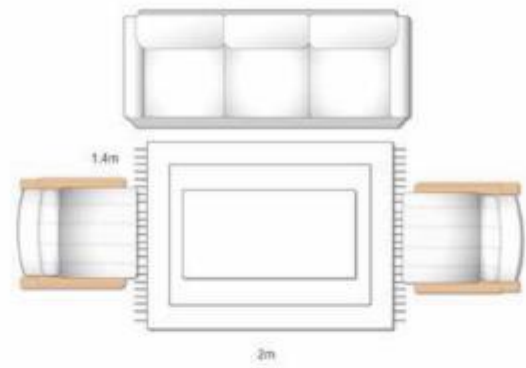

GOOD SIZE

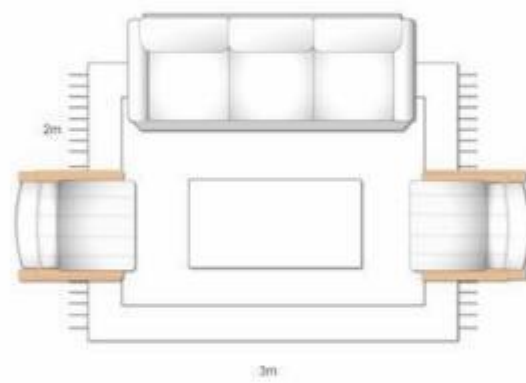

EVEN BETTER

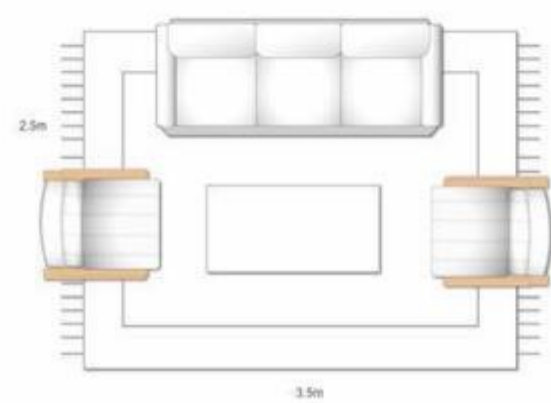

الصحيح والخطأ

TOO SMALL

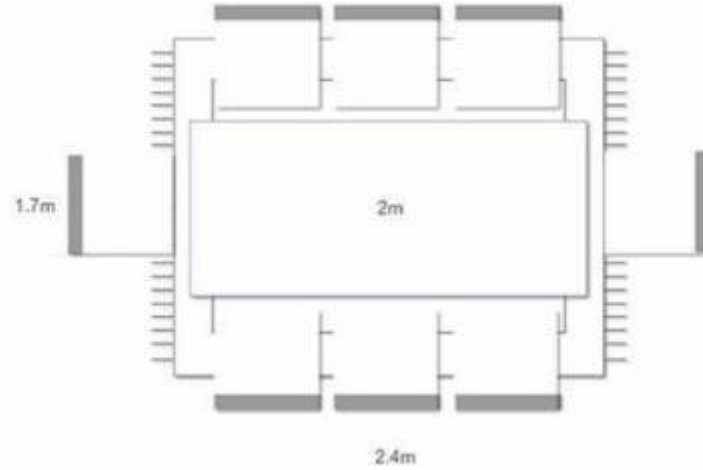

GOOD SIZE

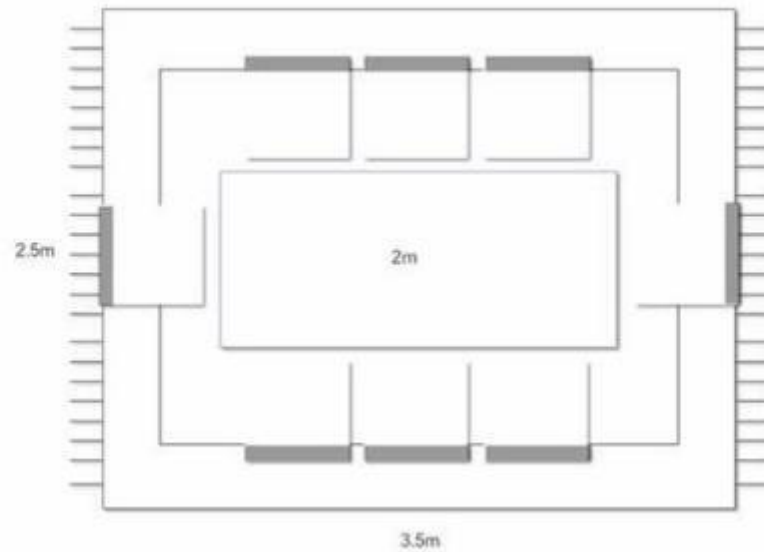

السجادة
التي
تحت
المنارة
تحت
المنارة
تحت
المنارة

السجادة
التي
تحت
المنارة
تحت
المنارة
تحت
المنارة

مقدمة عامة

السجاد أسفل الأثاث

PRINCIPALS
INTERIOR DESIGN

المراجع:

الصحيح والخطأ

السجاد أسفل الأثاث

السجاد أسفل الأثاث

مقدمة عامة

السجاد أسفل الأثاث

PRINCIPALS
INTERIOR DESIGN

المراجع:

SIDE TO SIDE



FRAME THE BED



WALL TO WALL



FRAME YOUR BED

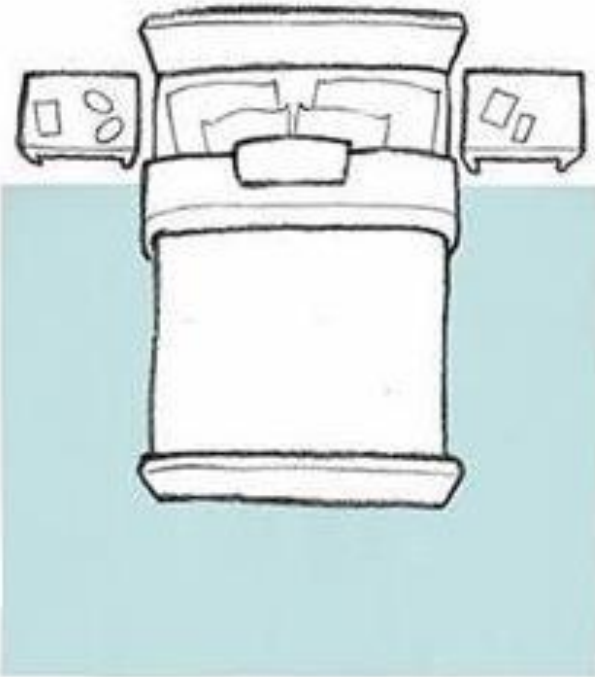

When laying down an area rug in your bedroom, it should extend 36" or so all around the bed. Alternatively, it could extend just on the sides, leaving the foot of the bed directly on the floor.
Standard sizes: 8' x 10' (queen), 9' x 12' (king)

RUNNERS ALL AROUND

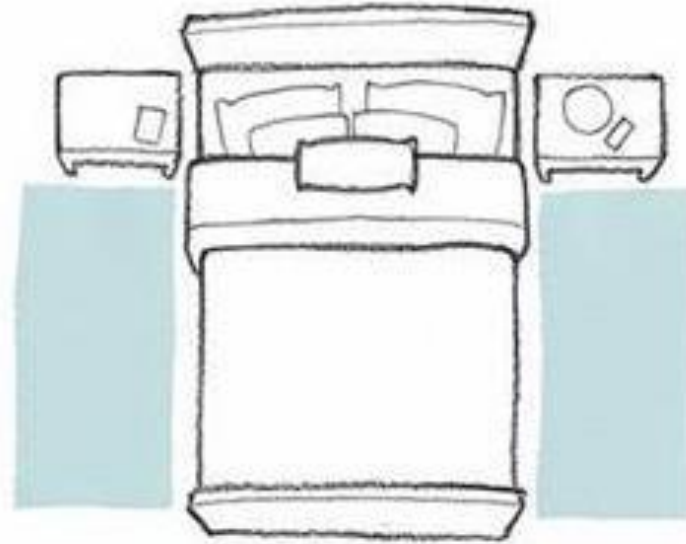

Runners are a great alternative to use on either side or along the foot of the bed. Even in a bedroom with wall-to-wall carpet, you can add runners on either side of the bed and across the foot for a cozier foundation.

Standard sizes: 2' 6" x 8', 3' x 5'

In the dining room there are two common choices for area rugs. The first is a rectangular area rug. This will of course work best if you have a rectangular or oblong dining table. The most common rectangular dining room rug is an 8' x 10' rug. Anything smaller and you run the risk of the chairs not being on the rug. If you have an unusually smaller or larger table you may of course need a different size rug.

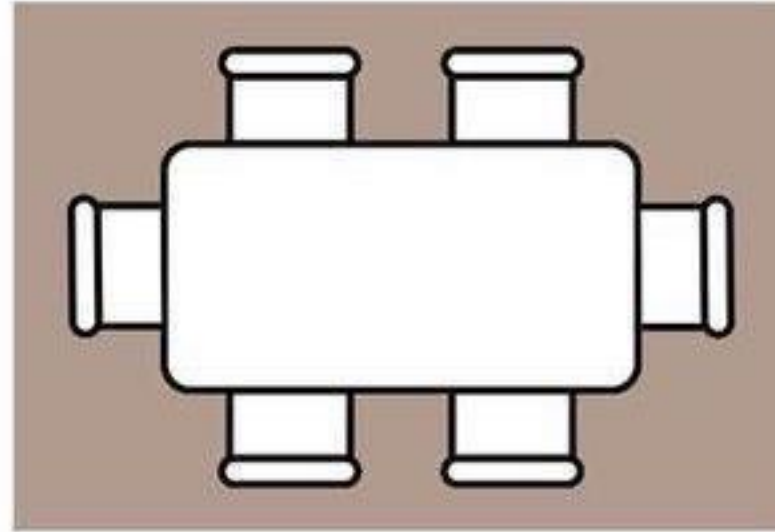

RECTANGULAR TABLE RECTANGULAR RUG

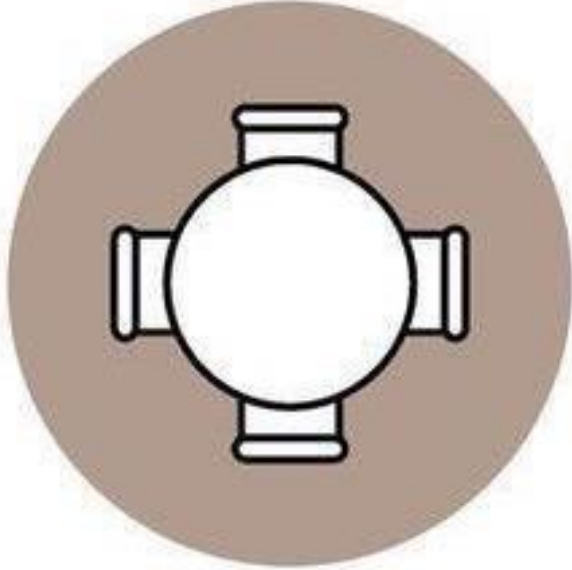

ROUND TABLE ROUND RUG

The second area rug option is a round rug to go with a round table. If you have a typical four-seater table, an 8' x 8' round rug is likely the best size for your room.

With this version of area rugs in the bedroom, you need a rug that is about 8" – 18" smaller than the length and width of the room. All of the furniture sits on the area rug leaving only a border of bare floor showing around the edges of the room.

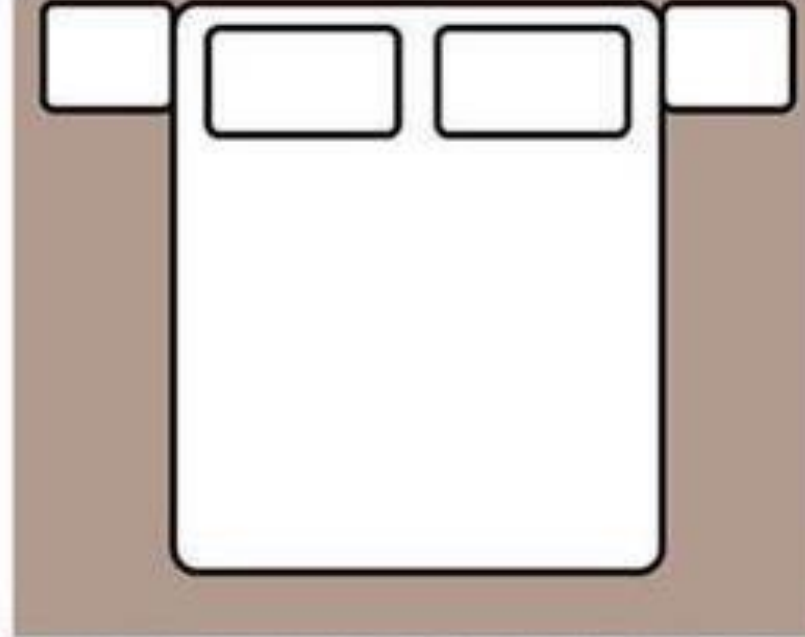

ALL THE FURNITURE ON THE RUG

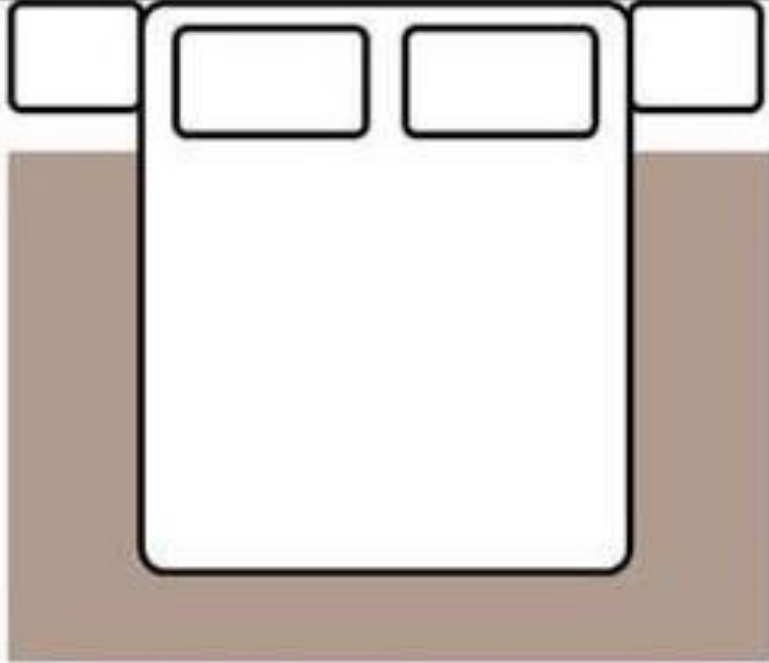

JUST THE BED ON THE RUG

With this area rug choice, the rug will peek out from under the bed, more so at the foot of the bed. Also the rug won't extend all the way to the head of the bed and the nightstands will not sit on the rug at all. Typically an 8' by 10' rug will be perfect in this situation, but turned so that the longer side is parallel to the head and foot of the bed.

If you'd like to keep the bedroom area rug budget to a minimum, this option is perfect. You can choose rug size based on the size of your bedroom, perhaps a 3' x 5' runner or even longer on each side of the bed.

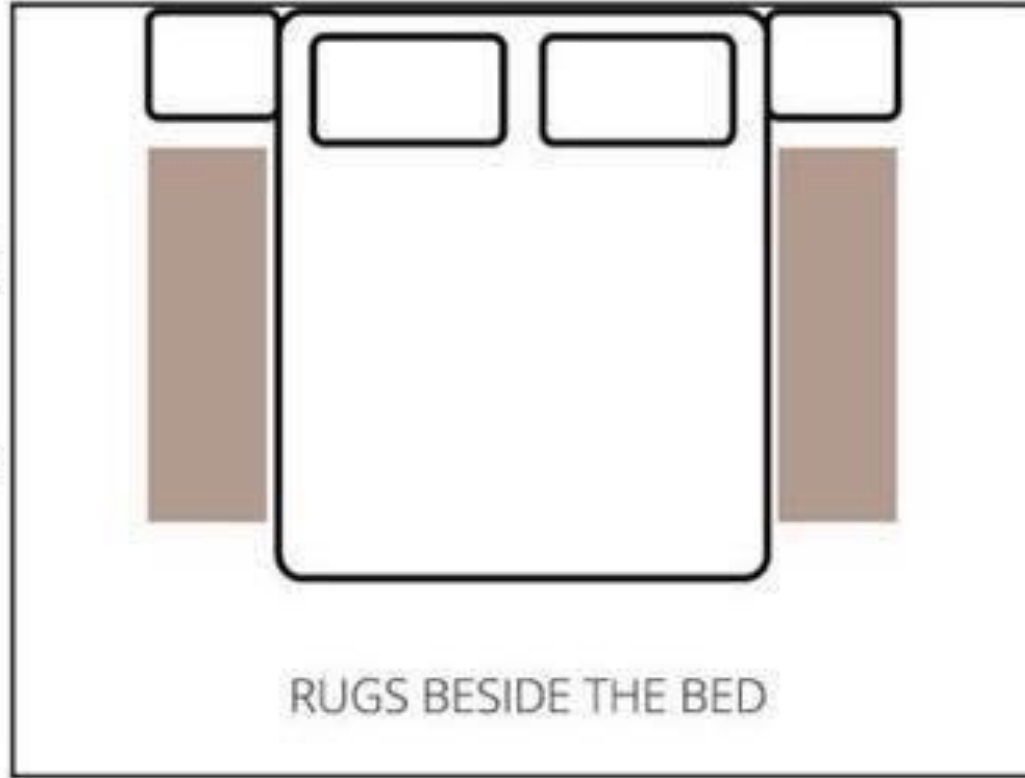

The most classic area rug sizing in the living room is to have all of the furniture entirely on the rug. You will need a rather large area rug, but the exact size will depend on the size of your furniture and the size of your room. This option is perfect for uniting a room that may not quite be entirely coordinated. A typical area rug size for this look in a living room is an 8' x 10' rug or larger.

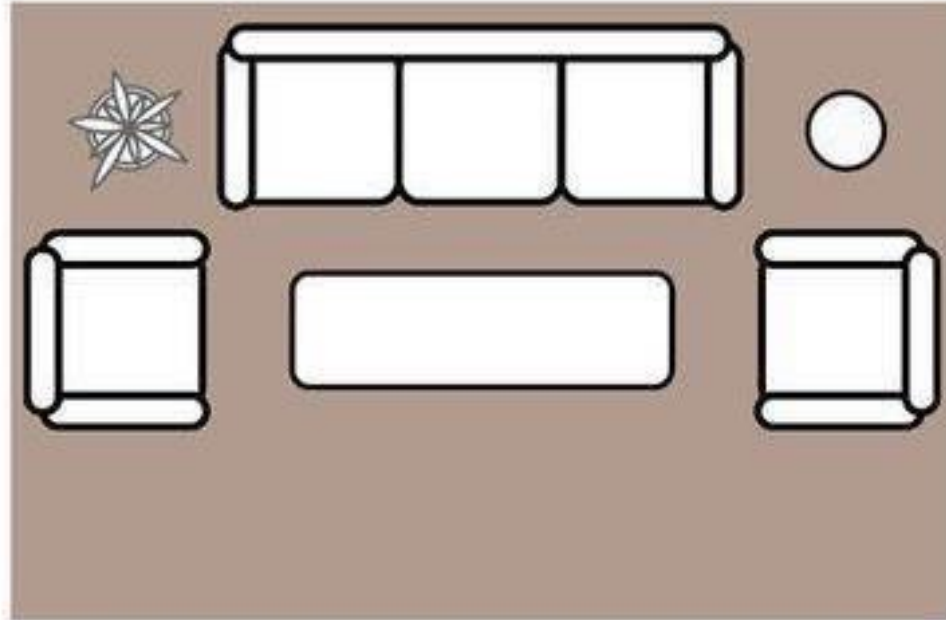

ALL THE FURNITURE ON THE RUG

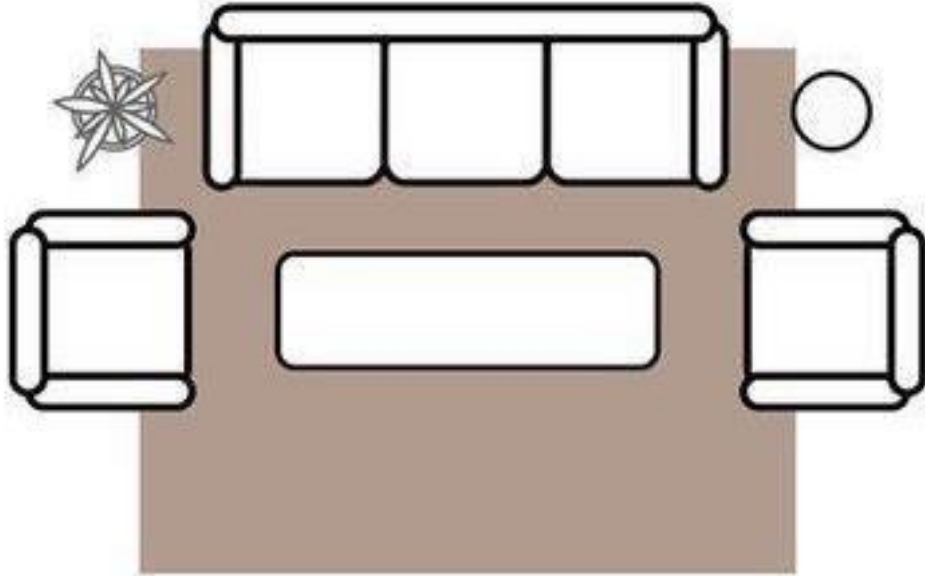

FRONT FEET ON THE RUG

Another very acceptable option in the living room is to have a rug just large enough for the front legs of all of the furniture to rest upon. This works well in a slightly smaller living room or a if you are on a tighter budget. A 5' x 7' area rug could work in this type of situation, but again measure to be sure all of the front legs will rest on the rug.

مع خالص الشكر والتقدير

KAMAL_ELGBALAWY@YAHOO.COM

الأساليب الصحيحة لفرش السجاد أسفل الأثاث

مادة أسس التصميم الداخلي

الفرقة الرابعة - ٢٠٢٠/٢٠٢١

د.م/ كمال محمود الجبلابي

THE REFERENCES TO MULTIPLE SOURCES ARE TEXT & FIGURES
(SKETCHES, DRAWINGS, PICTURES, PHOTOS,...ETC.)

ALL THE RIGHTS BELONG TO ORIGINAL AUTHORS

الأساليب الصحيحة لفرش السجاد أسفل الأثاث

الأساليب الصحيحة لفرش السجاد أسفل الأثاث

مقدمة عامة

السجاد أسفل الأثاث

PRINCIPALS
INTERIOR DESIGN

المراجع: